



 **HTPRO**[™]

Push-Fit Polypropylene Wastewater System
Technical Catalog

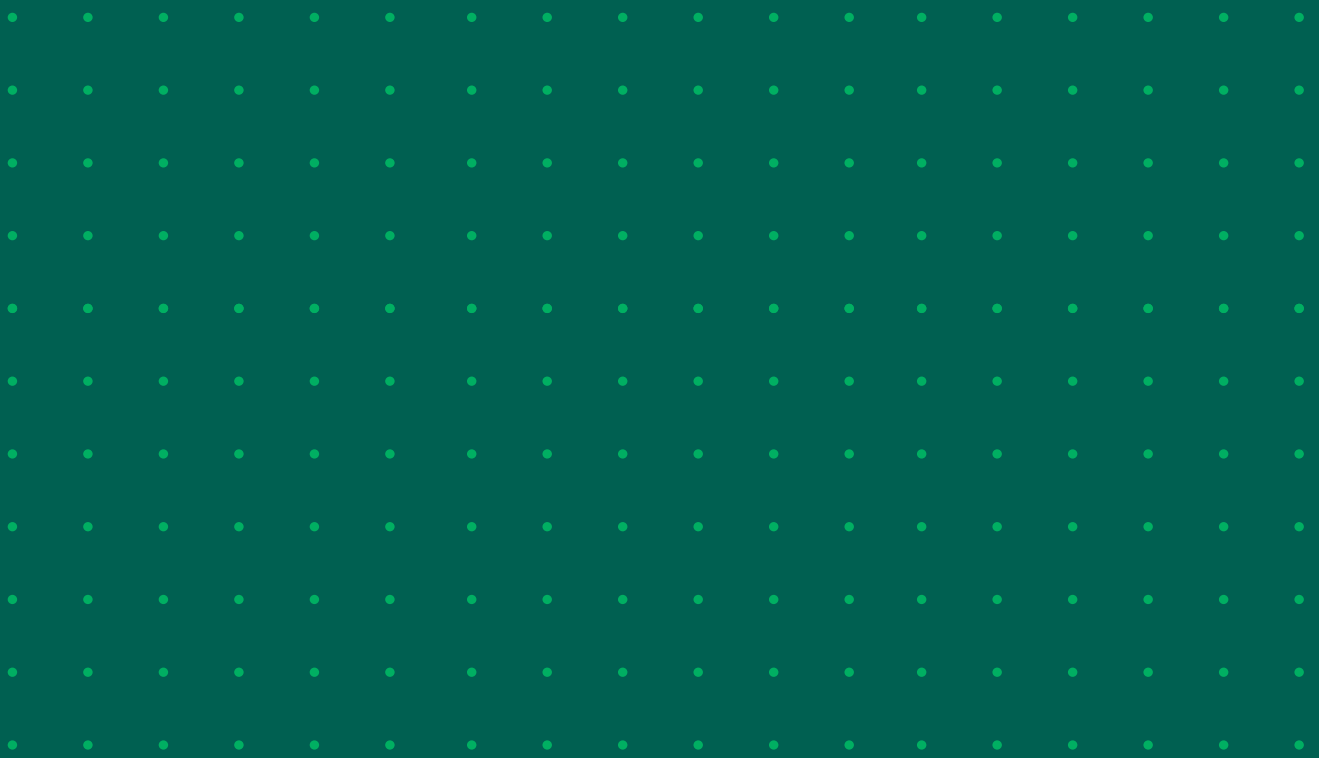

Table of Contents

Company Profile	4
Description of the HTPRO system	5
Main features	6
Marking	7
Product Approvals and Certificates	8
Datasheet	9
Installation of the HTPRO System	
1.1 Pipe preparation and assembly	10
1.2 Installation through ceilings, floors and walls	11
1.3 Repairs and installation	12
Product Range	
Single Socket Pipe	13
Double Socket Pipe	14
Bend 15°, Bend 30°, Bend 45°, Bend 67°	15
Band 87°, Haff Stack	16
Branch 45°, Branch 67°, End Cap	17
Branch 87°, Inspection Pipe, Double Socket, Sleeve	18
Bend with Right Connection, Left Connection, Double Connection, Front Top Connection, Double Branch with Inspection	19
Door Bend 45°, Door Bend 87°, Left Door 87°, Right Door 87°, Single Wye Branch with Inspection	20
Swept Branch with Inspection, Swept Tee Branch, Double Tee Branch, Corner Branch	21
Double Wye Branch and Inspection, Branch Left, Right, Back Inspection, Lubricant, Siphon Connector	22
Bend for Siphon Connection, Long Bend for Siphon connection, Rubber Gasket, Ventilation Pipe, Vent Cowl	23
Reducer, Short Reducer, Concentric Reducer, Reducer	24
Heavy Duty Clamp, WC Connector, Flange for WC Connections	25
Multi Trap with Risers and Gratings, Nahani Trap with Gratings, P-Trap with Risers	26
Transportation - Handling & storage	27

Company Profile

Huliot is a leading Israeli manufacturer of advanced pipe systems and innovative plastic products. With its over 70 years' experience. Huliot specializes in flow products: water supply, drainage, sewage and grey water recycling. Huliot's comprehensive product line of pipes and fittings for the building and infrastructure sectors are available in all standard diameters and sizes and in a range of plastic materials, including polypropylene (PP), polyvinyl chloride (PVC) and polyethylene (HDPE). All products are manufactured and produced by the latest extrusion and injection-moulding technologies. Huliot is renowned in the market for its uncompromising product quality. All its products are manufactured in accordance with European and Israeli standards. Huliot's manufacturing procedures comply with the most rigorous international standards for quality assurance, environmental protection and employee health and safety. HULIOT is certified for and compliant with ISO 9001:2005, ISO 14001:2015, ISO 45001:2018.

Huliot pipes and fittings pvt. Ltd. is fully owned subsidiary of Israeli parent company Huliot A.C.S.

Huliot brings the expertise, R & D to India to contribute to Indian plumbing industry.

Huliot India is manufacturing & selling green recyclable pipes made of polypropylene to replace PVC.

Unlike PVC which contains lead, Chlorine, Polypropylene is a pure and non hazardous to health it can be used in Residential, Commercial, Hotels, Hospitals, Schools, Industries like pharma and others.



Description of the

HTPRO™ System

Piping system for waste and drainage inside the building made of halogen and cadmium free co-polymer polypropylene.

Three layer pipes with thickness in S16 series. Joints are made with push fit sockets and elastomer seals.

Used in the construction of waste systems inside the building structure (application area B), anchored externally to the walls or embedded directly in the concrete. Can be used also for the creation of ventilation systems of waste water systems and for rain water drainage (only gravity systems).

B2 fire resistance class in compliance with DIN 4102

The system is manufactured in compliance with EN 1451 and certified by SKZ

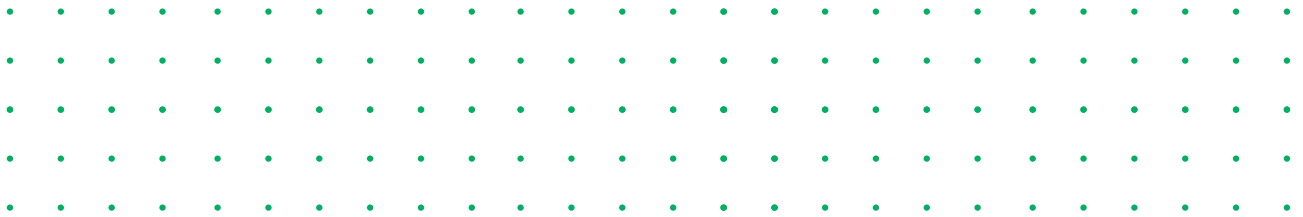

Main Features

- Three layers pipes
- Increased pipe thickness, S16 series, for excellent performances
- Easy and fast installation without tools
- Low thermal expansion
- High chemical resistance to metropolitan and industrial waster water
- 100% recyclability
- High impact resistance at low temperature (-10°C)
- White interior for easy visual inspection
- Extremely smooth flow
- 10-year guarantee

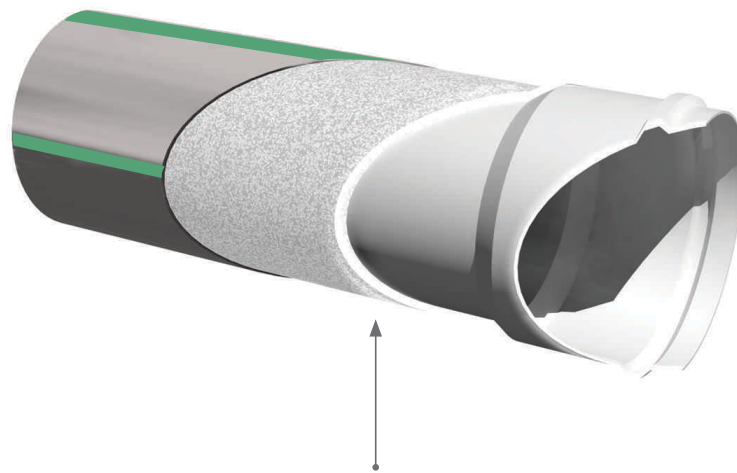

External Layer

Made of grey PP, provides excellent impact resistance even at low temperature and high mechanical performances.

Middle Layer

Made of PP compound, provides excellent performance.

Internal layer

Made of white PP co-polymer, gives high flow performance thanks to smooth surface, excellent resistance to chemical agents and high-definition contrast for visual inspection.



Recyclability

HT PRO™ system has Environment Product Declaration

Marking

Marking of pipe

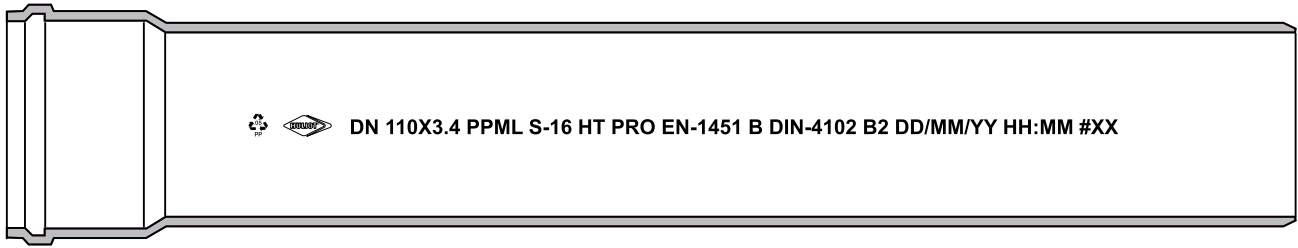

	Recycle mark
Huliot logo	Manufacturer
DN 110 x 3,4	Diameter and thickness
PPML	Material
S-16	Thickness series
HTPRO	Commercial product name
EN 1451	Construction standard
B	Application area
SKZ A778	Certificate n°
DIN 4102 B2	Fire class
DD/MM/YY	Production date
XX	Production site

Marking of fittings

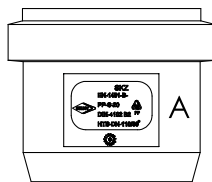
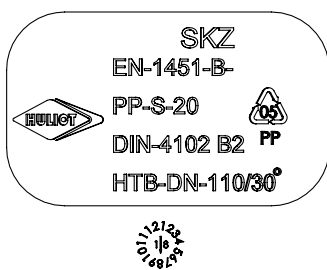

	Recyclability mark
Huliot logo	Manufacturer
EN 1451 - B - PP	Construction standard - application area - material
S-20	Thickness series
DIN 4102 B2	Fire class
HTB DN 110 30°	Type of product, diameter, angle
Date	Production date

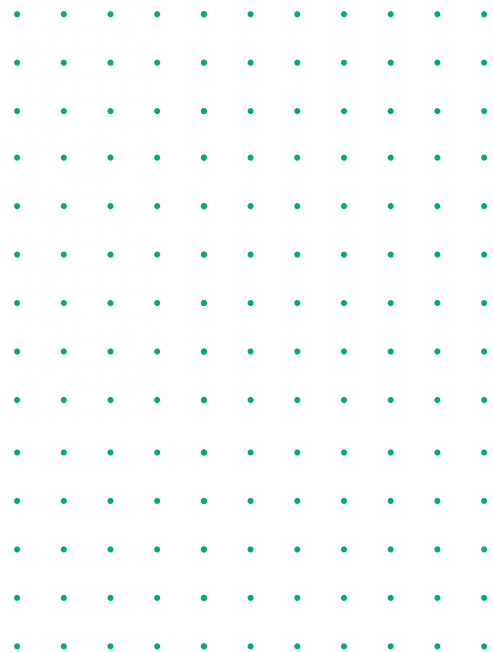

Certificates

Product Certificates

ZERTIFIKAT  Certification Body

CONFORMITY CERTIFICATE

Reg.-No. **5953**

Herewith we confirm in accordance with Article 16 and Article 21 of the Bavarian Building Regulations (BayBO), as published on 14 August 2007 (GVBl. 2007, p. 568, BayRS 2132-1-B), updated by Article 3 of the Act of 24 July 2019 (GVBl. p. 408) that the building products

Plastic fittings made of polypropylene (PP-HT) for waste discharge within the building structure

of the producer **Huliot, proizvodnja cevi in opreme d.o.o., Vrhniska cesta 30, 1354 HORJUL, SLOVENIA**

production plant **Huliot, proizvodnja cevi in opreme d.o.o., Vrhniska cesta 30, 1354 HORJUL, SLOVENIA**

according to the results of the internal production control and the third-party control carried out by the testing institute, recognized under building regulations,

SKZ - Testing GmbH
Friedrich-Bergius-Ring 22
97076 Würzburg
Germany

comply with the requirements of the standards

DIN EN 1451-1:1999-03 in conjunction with **DIN CEN/TS 1451-2:2012-05**
Additional valid: **DIN 4102-1:1998-05** and **DIN 4102-4:1994-03**,
DIN EN ISO 11925-2:2011-02 in conjunction with annex C 3.7 taking A 2.2.1.2, table 1.2.1, into account

as published at the Administrative Regulation for Technical Building Regulations (VTB) in the State of Bavaria of October 2018, Chapter C2.

Date of initial certification: 10 August 2015
Date of expiry: 30 June 2025

Würzburg, 1 July 2020

 i.V. 
Dipl.-Ing. Hans-Peter Krause
Head of Certification Body

The original language of this certificate is German. In case of doubt, the German version is obligatory.
SKZ - Testing GmbH, Friedrich-Bergius-Ring 22, 97076 Würzburg, Germany, Tel. +49 931 4104-0, testing@skz.de, www.skz.de

ZERTIFIKAT 

SKZ - Testing GmbH awards the following company

HULIOT proizvodnja cevi in opreme d.o.o.
Vrhniska cesta 30
1354 HORJUL
SLOVENIA

Production site: HULIOT proizvodnja cevi in opreme d.o.o., SI-1354 HORJUL
the right to use the SKZ testing and inspection mark



A 778

for the following plastic products

Drainage and sewerage pipes made of polypropylene with mineral modifiers PP-ML within the building structure dimension group 1 and 2

Trade name: HT PRO

SKZ specification for tests and inspection **HR 3.43:2021-02**

Users of the SKZ mark are obliged to observe the required regulations for the production and testing of these products.

Date of initial certification: 9 January 2018
Date of expiry: 8 January 2028

Würzburg, 9 January 2023



i.V. 
Dipl.-Ing. Hans-Peter Krause
Head of Certification Body

The original language of this certificate is German. In case of doubt, the German version is obligatory.
SKZ - Testing GmbH, Friedrich-Bergius-Ring 22, 97076 Würzburg, Germany, Tel. +49 931 4104-0, testing@skz.de, www.skz.de

Product certifications

- Pipes: SKZ A778
- Fittings: SKZ 5953

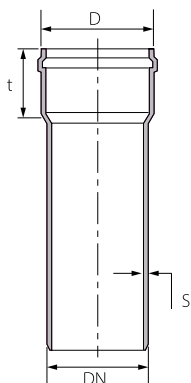
Pipes dimensions



DN	D	s (mm)	t	Application area	Pipe Series
40	55	1.8	44	B	S16
50	65	1.8	46	B	S16
75	90	2.3	49	B	S16
90	107	2.8	54	B	S16
110	130	3.4	65	B	S16
125	149	3.9	72	B	S16
160	185	4.9	75	B	S16
200	228	6.2	108	B	S16

Datasheet

Property	Value	Test Method
Application area	High and low temperature waste and drainage systems inside buildings (application area "B"), anchored to the walls or laid directly in concrete; ventilation of waste water systems, gravity rainwater drainage systems.	
Pipe structure and material	Three layer pipe in S16 thickness series; combination of co-polymer, homo-polymer and compound of polypropylene.	
Fitting Material	Co-polymer polypropylene with S20	
Connection	Push-fit sockets with rubber seal	
Seal	SBR rubber lip ring	
Color	Fittings Grey RAL 7037 Pipes Grey RAL 7037 for the external layer, dark grey for the middle layer, white for the internal layer	
Diameters	40-200 mm	
Packaging	Pipes in wooden frames, in bundles and boxes depending on diameter and length. Fittings in cardboard boxes	
Minimum working temperature	-10°C	
Max temperature of waste water	+95°C (discontinuous) +80°C (continuous)	
Chemical resistance	Discharge media between pH2 and pH 12	
Halogen & cadmium content	Free of Halogen or Cadmium	
Fire resistance	B2	DIN 4102
UV resistance	Suitable for external installation when protected to direct sun exposure (for instance by mean of special UV protective coating); can be stocked outside up to 18 months	
Construction Standard	EN 1451-1	
Conformity certificate	SKZ 5953, SKZ A778	



Installation of the HTPRO™ Systems

1.1 | Pipe preparation and assembly

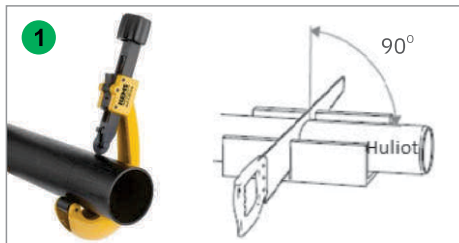

Cut the Huliot pipe using a suitable pipe cutter available in market or a fine tooth saw that is suitably guided to guarantee a perpendicular cut.

Chamfering and beveling the Huliot pipe ends to an angle of roughly 15o to 30o using a suitable chamfering tool or a fine file. The chamfered surface must be smooth to avoid damaging the ring seal inside the socket when the pipe is inserted.

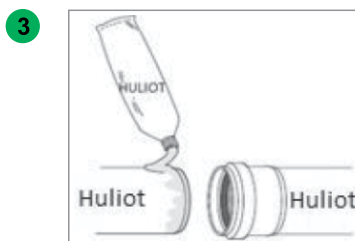

Ensure that the inside of the socket, the seal and the spigot end of the pipe piece to be inserted are perfectly clean. Lubricate the spigot/pipe/fitting end and rubbering with the appropriate Huliot lubricant only.

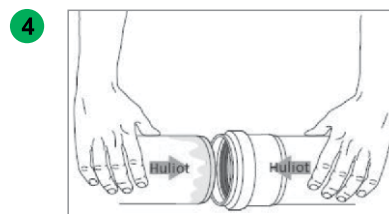

Join the pipes and fittings or fittings to fittings together by inserting the end/spigot into the socket to maximum socket depth.

Hanging distances

Pipe DN (External diameter)	Max. bracket distance for Horizontal installation - D1 max	Max. bracket distance for Vertical installation - D max
Ø 40	0.8	1.0
Ø 50	0.8	1.0
Ø 75	0.8	1.1
Ø 90	0.9	1.4
Ø 110	1.1	1.5
Ø 125	1.1	1.5
Ø 160	1.5	1.5
Ø 200	1.5	1.5

Pipe DN (External diameter)	Hanging distance from the ceiling (X)	Ceiling Rod diameter
110, 125, 160, 200	Up to 0.4 meters	3/8"
	Over 0.4 meters Up to 0.6 meters	1/2"
	Over 0.6 meters	3/4"

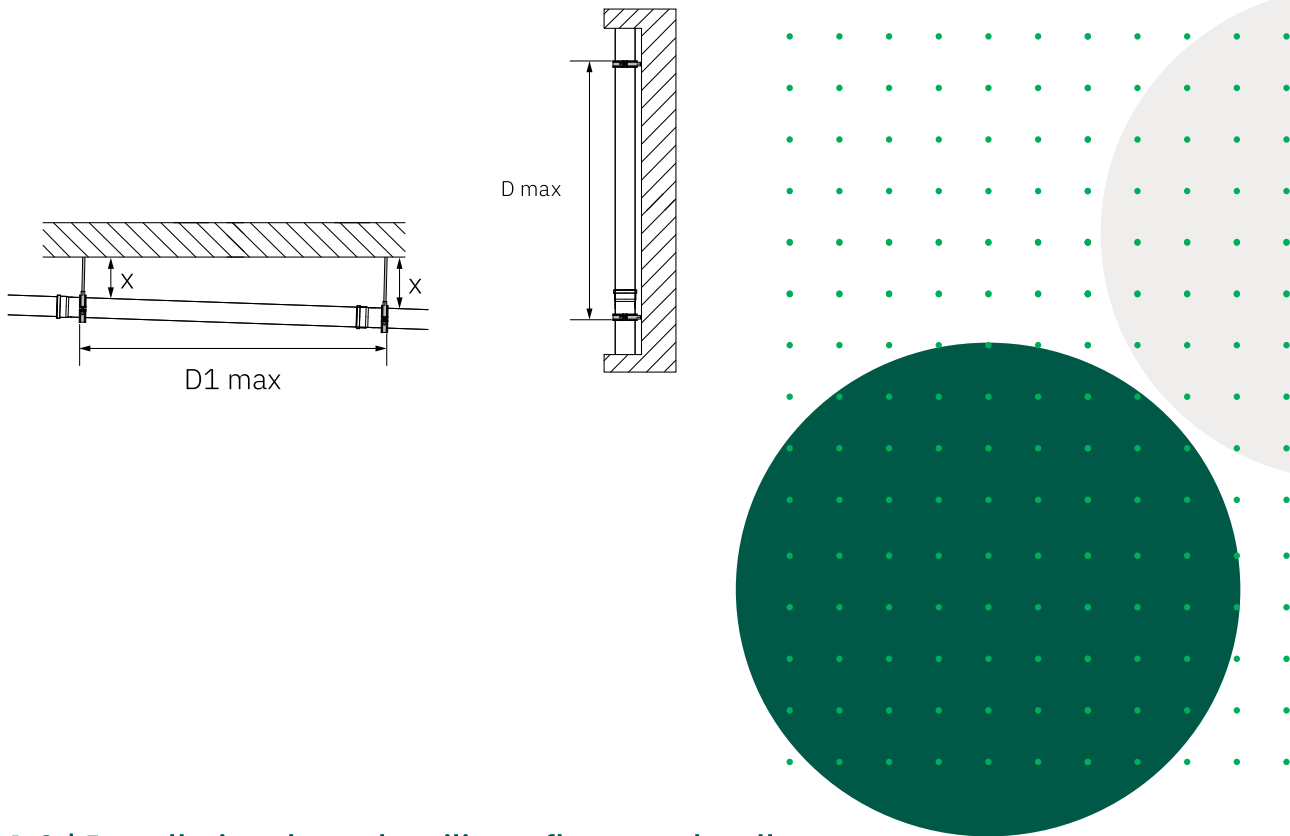

1.2 | Installation through ceilings, floors and walls

It is important to avoid contact between system components and rigid elements, such as walls, ceilings, floors etc., in order to prevent structure-borne noise transmission.

For pipes traversing walls and ceilings, a space of at least 30 mm should be maintained between the pipe and any rigid material.

If the spaces around the pipes traversing walls and floors must be filled, use only soft construction materials such as foam or glass fiber (Figure 1).

In case of pipes traversing floors where protection against humidity is needed we recommend to use Huliote Ultraseal (see description in following page).

For improved hydraulic flow and reduced noise, 87° bends are not recommended to be used for changing flow direction from vertical to horizontal. It is preferable to use two 45° bends, with 2D minimum length of connection pipe between them (Figure 2).

When installing pipes in open spaces (such as basements, parking garages etc.), above suspended ceilings or behind screen walls, prevent any contact of other material (such as suspended ceiling, electrical, water, ventilation and air conditioning systems etc.) with the pipes (Figure 3).

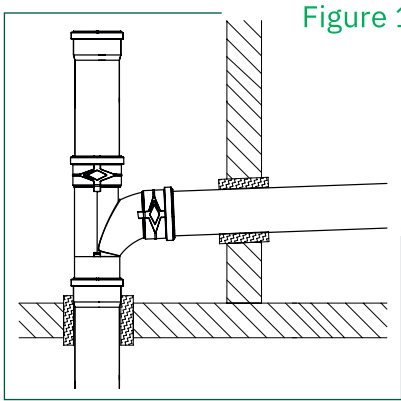

Figure 1

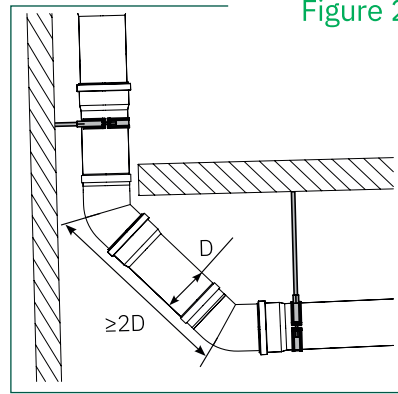

Figure 2

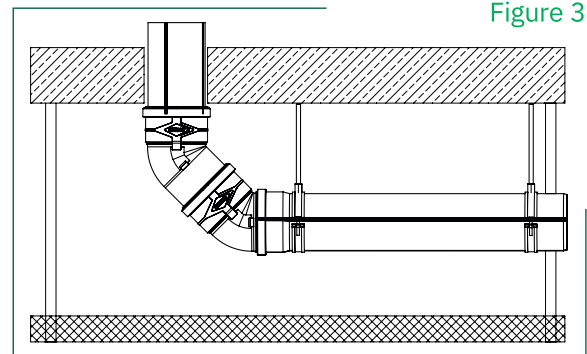
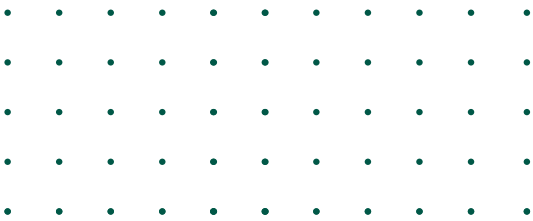

Figure 3

1.3 | Repairs and installation

To add a branch to an existing pipe with long socket and sleeve, insert the long socket plain end into the branch socket, the equivalent of the socket length from the existing pipe piece. Insert the long socket into the upper pipe all the way. Fix the sleeve on the lower pipe and slide the branch and long socket down into the sleeve (Figure 4). An alternative possibility is to use two sleeves and plain pipe (the minimum plain pipe length must be more than double that of the external pipe diameter DN, as in (Figure 5).

To Fix punctured or damaged pipe, the same methods can apply with one socket pipe (HTPRO) instead of the branch and for adding inspection pie (HTPRO) or double branch (HTPRO).

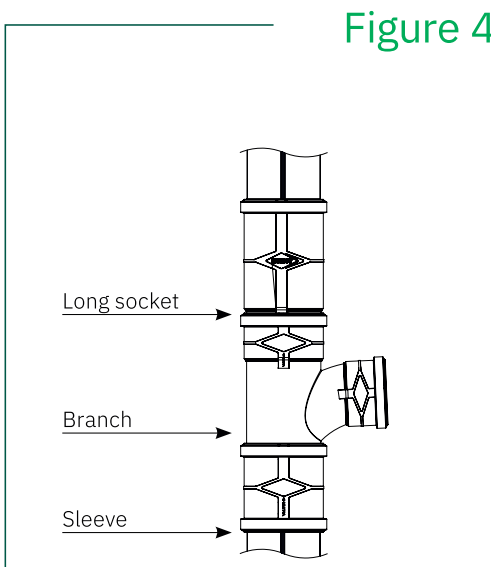

Figure 4

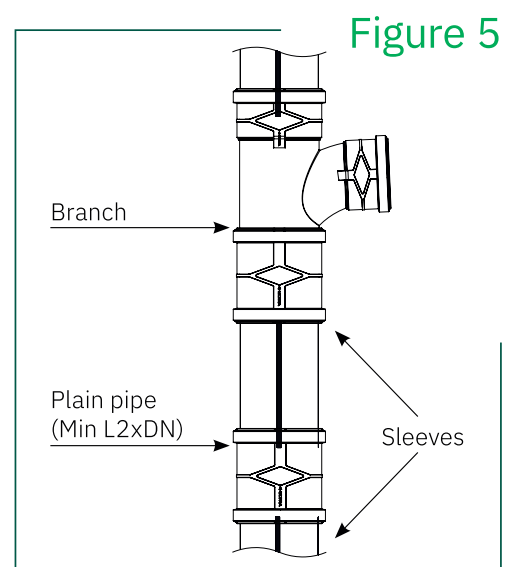
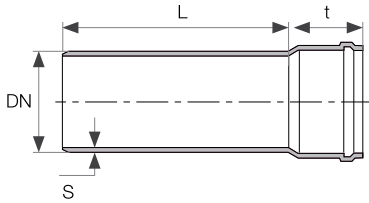

Figure 5

HTPRO Single Socket Pipe



Huliot Code	DN	S	T	L
54040025	40	1.8	49	250
54040050	40	1.8	49	500
54040100	40	1.8	49	1000
54040150	40	1.8	49	1500
54040200	40	1.8	49	2000
54040300	40	1.8	49	3000
54050025	50	1.8	51	250
54050050	50	1.8	51	500
54050100	50	1.8	51	1000
54050150	50	1.8	51	1500
54050200	50	1.8	51	2000
54050300	50	1.8	51	3000
54075025	75	2.3	58	250
54075050	75	2.3	58	500
54075100	75	2.3	58	1000
54075150	75	2.3	58	1500
54075200	75	2.3	58	2000
54075300	75	2.3	58	3000
540110025	110	3.4	70	250
540110050	110	3.4	70	500
540110100	110	3.4	70	1000
540110150	110	3.4	70	1500
540110200	110	3.4	70	2000
540110300	110	3.4	70	3000
540125025	125	3.9	78	250
540125050	125	3.9	78	500
540125100	125	3.9	78	1000
540125150	125	3.9	78	1500
540125200	125	3.9	78	2000
540125300	125	3.9	78	3000
540160025	160	4.9	90	250
540160050	160	4.9	90	500
540160100	160	4.9	90	1000
540160200	160	4.9	90	1500
540160250	160	4.9	90	2000
540160300	160	4.9	90	3000
540200100	200	6.2	108	1000
540200200	200	6.2	108	2000
540200300	200	6.2	108	3000

HTPRO Double Socket Pipe

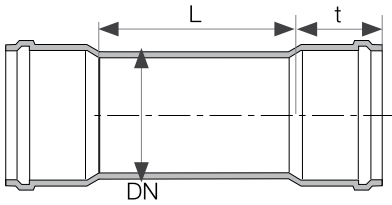
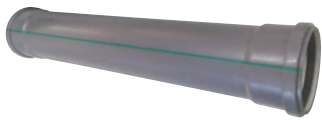

Huliot Code	DN	S	T	L
5404040050	40	1.8	49	500
5404040100	40	1.8	49	1000
5404040150	40	1.8	49	1500
5404040200	40	1.8	49	2000
5404040300	40	1.8	49	3000
540505050	50	1.8	51	500
5405050100	50	1.8	51	1000
5405050150	50	1.8	51	1500
5405050200	50	1.8	51	2000
5405050300	50	1.8	51	3000
5407575050	75	2.3	58	500
5407575100	75	2.3	58	1000
5407575150	75	2.3	58	1500
5407575200	75	2.3	58	2000
5407575300	75	2.3	58	3000
5401111050	110	3.4	70	500
5401111100	110	3.4	70	1000
5401111150	110	3.4	70	1500
5401111200	110	3.4	70	2000
5401111300	110	3.4	70	3000
5401212050	125	3.9	78	500
5401212100	125	3.9	78	1000
5401212150	125	3.9	78	1500
5401212200	125	3.9	78	2000
5401212300	125	3.9	78	3000
5401616050	160	4.9	90	500
5401616100	160	4.9	90	1000
5401616150	160	4.9	90	1500
5401616200	160	4.9	90	2000
5401616300	160	4.9	90	3000
5402020050	200	6.2	108	500
5402020100	200	6.2	108	1000
5402020150	200	6.2	108	1500
5402020200	200	6.2	108	2000
5402020300	200	6.2	108	3000

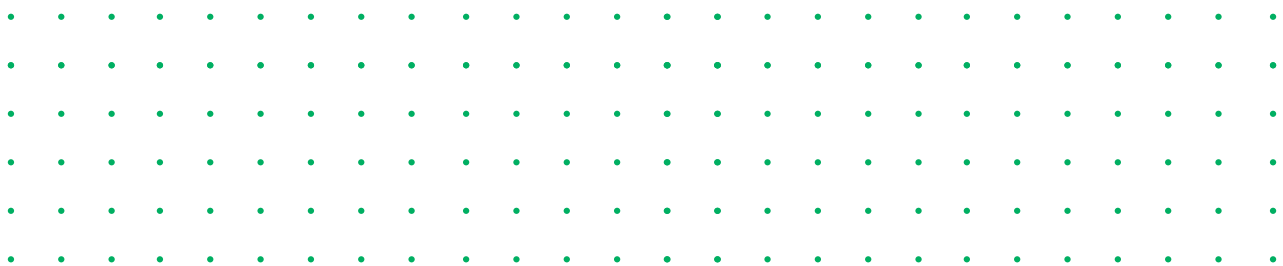

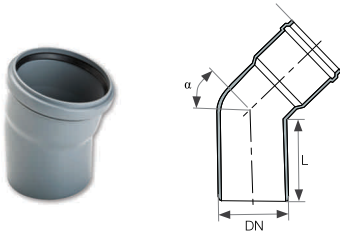

HTPRO Bend 15°

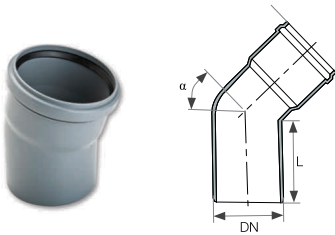

Huliot Code	DN	α°	
40010150	40	15°	20
40020150	50	15°	20
40030150	75	15°	20
40040150	110	15°	20
40050150	125	15°	20
40060150	160	15°	10

HTPRO Bend 30°



Huliot Code	DN	α°	
40010350	40	30°	20
40020350	50	30°	20
40030350	75	30°	20
40040350	110	30°	20
40050350	125	30°	20
40060350	160	30°	10

HTPRO Bend 45°

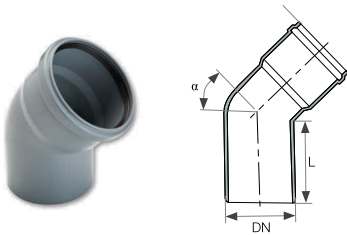

Huliot Code	DN	α°	
40010460	40	45°	20
40020460	50	45°	20
40030460	75	45°	20
40040460	110	45°	20
40050460	125	45°	10
40060460	160	45°	10

HTPRO Bend 67°

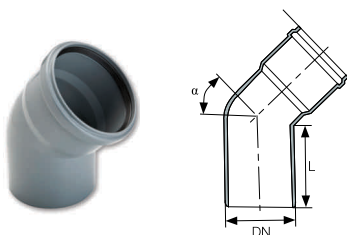

Huliot Code	DN	α°	
40010650	40	67°	20
40020650	50	67°	20
40030650	75	67°	20
40040650	110	67°	20
40060650	125	67°	15

HTPRO Bend 87°

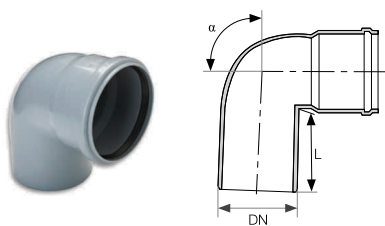

Huliot Code	DN	α°	
40010860	40	87°	20
40020860	50	87°	20
40030860	75	87°	20
40040860	110	87°	20
40050860	125	87°	10
40060860	160	87°	10

HTPRO HAFF STACKx1x2x3x4x5x6

Code	D	DN	D1/D2/D3	D4/D5/D6	L	L1	L2	L3	L4	H	H1	H2	H3
Haff Stack x1 x2 x3 x4 x5 x6	90	100	110	75	276	90	130	55	180	743	246	169	328

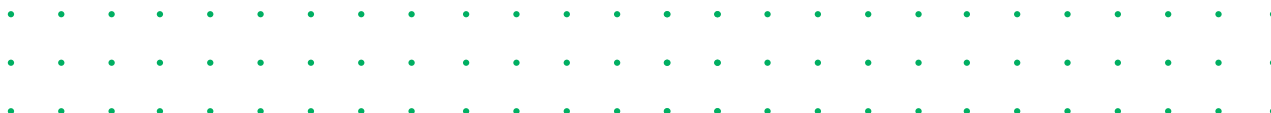
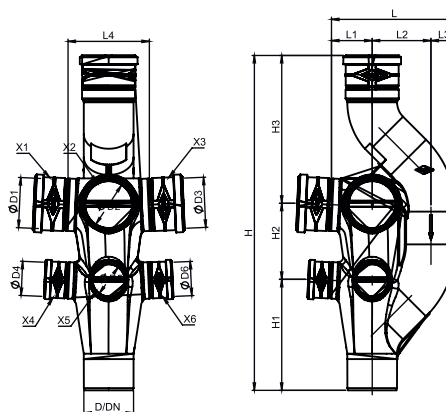

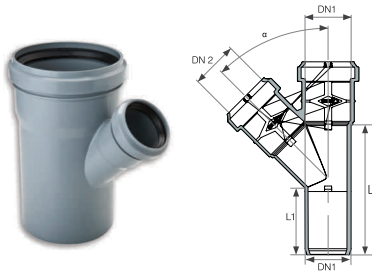

HTPRO Branch 45°

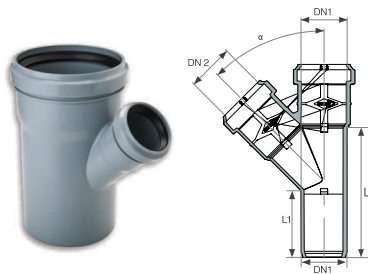

Huliot Code	DN 1	DN 2	α°	
40611440	40	40	45°	20
40621440	50	40	45°	20
40622460	50	50	45°	20
40632460	75	50	45°	20
40633460	75	75	45°	20
40642460	110	50	45°	20
40643460	110	75	45°	20
40644460	110	110	45°	20
40654460	125	110	45°	10
40655460	125	125	45°	20
40664450	160	110	45°	10
40666450	160	160	45°	10

HTPRO Branch 67°



Huliot Code	DN 1	DN 2	α°	
O040ABOX67	40	40	67°	20
O0500000670040	50	40	67°	20
O050ABOX67	50	50	67°	20
O0750000670050	75	50	67°	20
O075000067	75	75	67°	20
O110ABOX670050	110	50	67°	20
O1100000670075	110	75	67°	20
O110ABOX67	110	110	67°	20

HTPRO End Cap

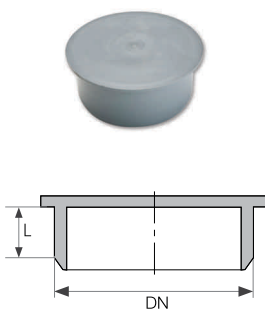

Huliot Code	DN	L	
41610040	40	32	20
41620050	50	33	20
41630050	75	42	20
41640050	110	70	20
41650060	125	74	20
41660060	160	85	10

HTPRO Tee Branch 87°

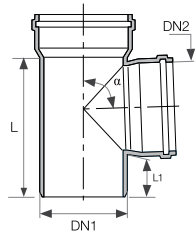

Huliot Code	α°	DN 1	DN 2	L	L1	
40611860	87°	40	40	98	55	20
40621860	87°	50	40	109	64	20
40622860	87°	50	50	109	59	20
40633860	87°	75	75	164	76	20
40632860	87°	75	50	165	91	20
40642860	87°	110	50	130	79	20
40643860	87°	110	75	203	95	20
40644860	87°	110	110	171	64	20
40654860	87°	125	110	231	76	10
40655860	87°	125	125	255	78	20
40666860	87°	160	160	288	110	10
40664860	87°	160	110	240	107	10

HTPRO Inspection Pipe

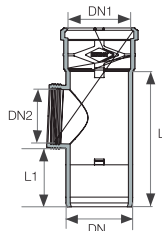

Huliot Code	DN1	DN2	L	L1	
49120060	50	50	-	-	20
49130060	75	75	164	81	20
49140060	110	110	223	96	20
49150060	125	125	219	90	20
49160060	160	160	232	104	10

HTPRO Double Socket

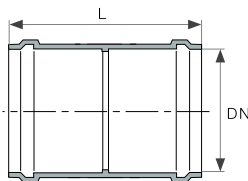

Huliot Code	DN	L	
41710050	40	85	20
41720055	50	98	20
41730050	75	108	20
41740250	110	132	20
41750065	125	144	20
41750055	160	166	10

HTPRO Sleeve

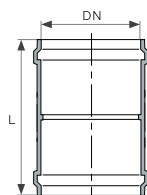

Huliot Code	DN	L	
41710053	40	85	20
41720053	50	98	20
41730053	75	108	20
41740250	110	132	20
41750065	125	144	20
41760055	160	166	10

HTPRO Bend With Right Connection



Huliot Code	DN 1	DN 2	α°	
4040142848	110	50	87°	10

HTPRO Bend With Left Connection



Huliot Code	DN 1	DN 2	α°	
4040142849	110	50	87°	10

HTPRO Bend With Double Connection



Huliot Code	DN 1	DN 2	α°	
4041242807	110	50	87°	10

HTPRO Bend With Front Top Connection



Huliot Code	DN 1	DN 2	α°	
4040142807	110	50	87°	10

HTPRO Double Branch with Inspection

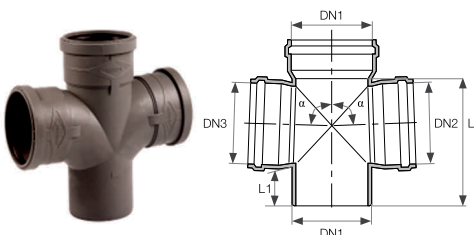

Huliot Code		DN 1	DN 2	DN 3	α°	
41044857	Insp.	110	110	110	87.5°	8
41064857	Insp.	160	110	110	87-87.5°	6
41044860		110	110	110	87-87.5°	8
41064850		160	110	110	87-87.5°	6

HTPRO Door Bend 45°

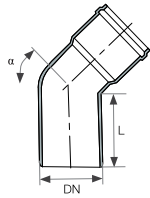

Huliot Code		DN	α°	L	
40020467	Insp.	50	45	64	60
40030467	Insp.	75	45		35
40040467	Insp.	110	45	94	18
40060457	Insp.	160	45	116	8

HTPRO Door Bend 87°

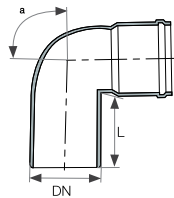

Huliot Code		DN	α°	L	
40020867	Insp.	50	87	80	60
40030867	Insp.	75	87	100	35
40040867	Insp.	110	87	129	18
40060867	Insp.	160	87		8

HTPRO Left Door 87°

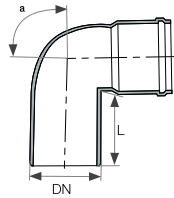

Huliot Code		DN	α°	L	
40040869	L. Insp.	110	87	129	16
40060869	L. Insp.	160	87		6

HTPRO Right Door 87°

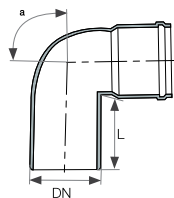

Huliot Code		DN	α°	L	
40040868	R. Insp.	110	87	129	16
40060868	R. Insp.	160	87		6

HTPRO Single Wye Branch With Inspection

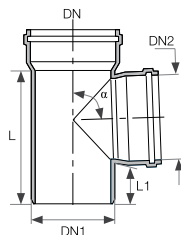

Huliot Code		DN	DN 1	DN 2	α°	L	L 1	
40644467	Insp.	110	110	110	45	224	70	16
40664457	Insp.	160	110	110	45	320	87	6

HTPRO Swept Branch With Inspection 87.5°

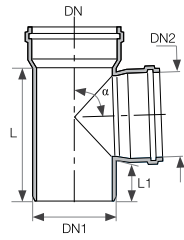

Huliot Code		DN 1	DN 2	α	L	L1	
40643867	Insp.	110	75	87.5	203	95	10
40744867	Insp.	110	110	87.5	181	67	10
40754867	Insp.	125	110	87.5	231	76	7
4040664407	Insp.	160	110	87.5	258	87	4

HTPRO Swept Tee Branch 87.5°

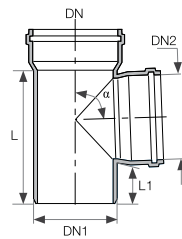

Huliot Code	DN 1	DN 2	α°	L	L1	
40643860	110	75	87.5	203	95	10
40744860	110	110	87.5	171	64	10
40754860	125	110	87.5	240	110	7
14040764860	160	110	87.5	258	87	4

HTPRO Double Tee Branch

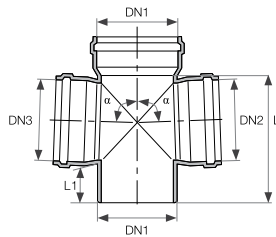

Huliot Code	DN 1	DN 2	DN 3	α°	L	L1	
41052860	125	50	50	87	210	72	6
41054850	125	110	110	87	192	72	6
41062850	160	50	50	87	257	82	4
41064850	160	110	110	87	257	82	4

HTPRO Corner Branch

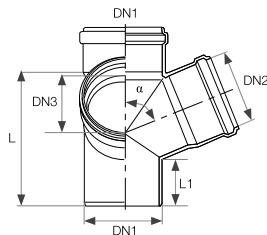

Huliot Code	DN 1	DN 2	DN 3	α°	L1	L2	
41244850	110	110	110	87	197	56	6
41252860	125	50	50	87	209	70	6
41262850	160	50	50	87	268	78	4
41264850	160	110	110	87	270	78	4

HTPRO Double Wye Branch And Inspection

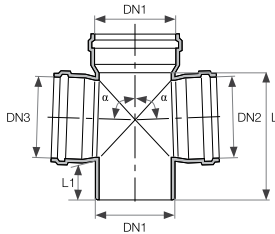

Huliot Code	DN 1	DN 2	DN 3	α°	L	L1	
41042450	110	50	50	45	-	-	10
41044450	110	110	110	45	228	68	10
41064450	160	110	110	45	-	-	4
41044457 Insp.	110	110	110	45	-	-	6

HTPRO Branch Left, Right Back Inspection

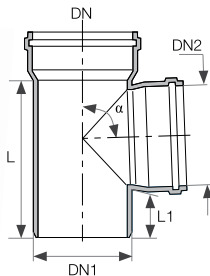

Huliot Code		DN 1	DN 1	α°	L	L1	
40644867	Insp.	110	110	87	176	68	10
40644868	R. Insp.	110	110	87	176	68	10
40644869	L. Insp.	110	110	87	176	68	10
40664857	Insp.	160	110	87	258	87	4
40666857	Insp.	160	160	87	258	90	4

Lubricant

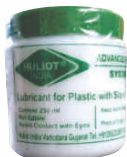

Huliot Code	
47700012	40

HTPRO Siphon Connector

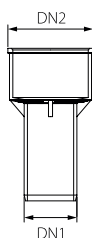

Huliot Code	DN 1	DN 2	
P032000046	32	46	20
P040000046	40	46	20
P040000050	40	50	20

HTPRO Bend for Siphon Connection

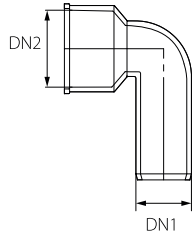

Huliot Code	DN 1	DN 2	
K03200004600S	32	46	20
K04000005000S	40	50	20
K04000004600S	40	46	20
K05000005000S	50	50	20

HTPRO Long Bend for Siphon Connection

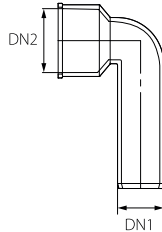

Huliot Code	DN 1	DN 2	
K04000005000DS	40	50	20
K04000004600DS	40	46	20

Rubber Gasket for HTS, HTSW, HTSWL



Huliot Code	ID	OD	
T047T000000000	26/32	46	500
T046T000000000	40	46	1000
T050T000000032	26/32	50	500
T050T000000040	40	50	500

HTPRO Ventilation Pipe



Huliot Code	DN 1	L	
0050ABOX0000K	50 Short	280	20
0075ABOX0000K	75 Short	280	20
0110ABOX0000K	110 Short	280	20
0050ABOX0000KD	50 Long	730	10
0075ABOX0000KD	75 Long	730	5
0110ABOX0000KD	110 Long	730	5

HTPRO Vent Cowl

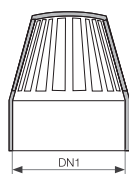

Huliot Code	Product	DN 1	
4042320040	Vent Cowl	50	50
4042330040	Vent Cowl	75	50
4042340060	Vent Cowl	110	50
4042360040	Vent Cowl	160	50

HTPRO Reducer

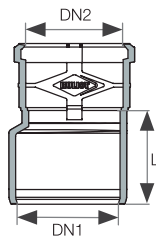

Huliot Code	Size	DN 1	DN 2	L	
42121060	50x40	40	50	60	20
42132050	75x50	50	75	72	20
42142050	110x50	50	110	100	20
42143050	110x75	75	110	62	20
42154060	125x110	110	125	114	20
42164050	160x110	110	160	112	20
42165050	125x160	125	160	-	20

HTPRO Short Reducer



Huliot Code	DN 1	DN 2	
P07500000050K	50	75	30
P090000000050	50	90	20
P110NN0000040K	40	110	20
P110000000050V	50	110	20
P110000000075V	75	110	20

HTPRO Concentric Reducer



Huliot Code	DN 1	DN 2	
P040000000032K	32	40	50
P050000000040K	40	50	50
P090000000075	75	90	20
P110000000090	90	110	20

HTPRO Reducer



Huliot Code	DN 1	DN 2	
P040000000032R	40	32	30
P040000000050	50	40	30

HTPRO Heavy Duty Clamps



Huliot Code	DN	M	Strip Size	Max Load (Kg)
48100040	40	M8/M10	1.6x19	300
48100050	50	M8/M10	1.6x19	300
48100075	75	M8/M10	1.6x19	500
48100011	110	M8/M10	1.6x19	500
48100012	125	M8/M10	1.6x19	500
48100016	160	M8/M10	1.6x19	500
48100020	200	M8/M10	1.6x19	500

HTPRO WC Connector

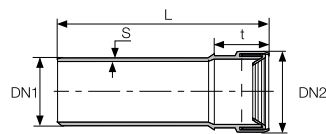

Straight WC Connector

Huliot Code	DN	
41540020	110	12

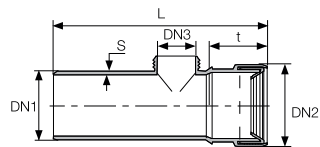

Straight WC Connector With Inspection

Huliot Code	DN	
41540027	110	12

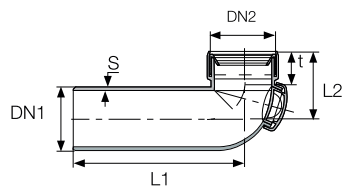

Bend WC Connector With Inspection

Huliot Code	DN	
41542866	110	12

HTPRO Flange for WC Connections

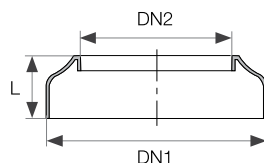

Huliot Code	DN1	DN2	
41542866	160	110	60

HTPRO Multi Trap with Risers and Gratings

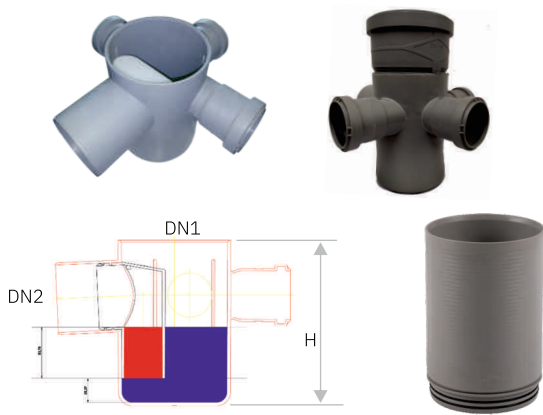

Huliot Code		DN1	DN2	H
60117051		110	75	173
69201551	Riser for MFT & Nahanitrap	110	-	150
69203551	Riser for MFT & Nahanitrap	110	-	350
14048111060-G	Multi Trap with Socket	110	75	245

Technical Data

Product Material	: PP
Depth of water seal	: 50 mm
Discharge rate	: 1 (L/S)

Nahani Trap with Gratings

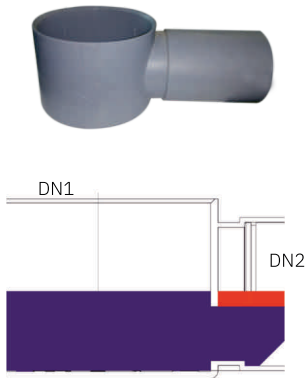

Huliot Code	DN1	DN2	H
69111750	110	75	88

Technical Data

Product Material	: PP
Depth of water seal	: 7.15 mm
Discharge rate	: Not Recommended

HTPRO P-Trap with Risers

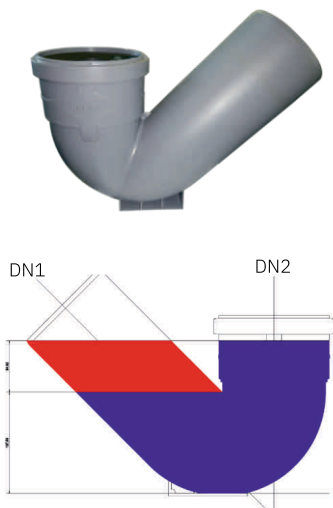

Huliot Code	DN	DN2
49540750	110	110

Technical Data

Product Material	: PP
Depth of water seal	: 50 mm
Discharge rate	: 1.5 (L/S)

Transportation, Handling and Storage

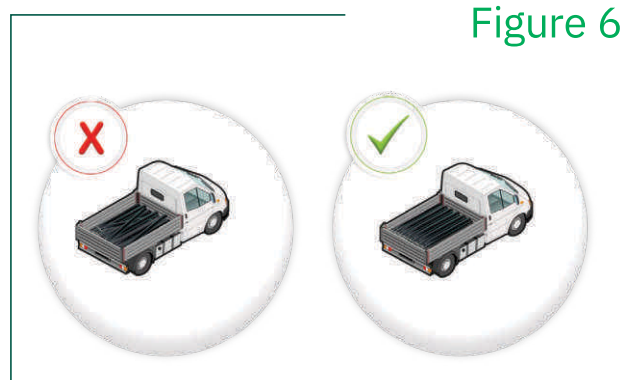
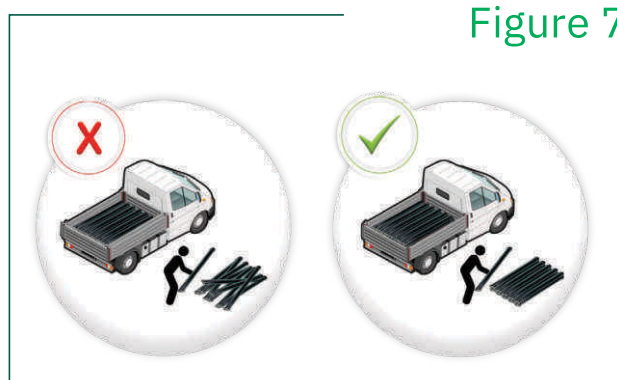

It is recommended to handle the pipes and fittings in their original sales packaging to protect them and prevent damage during loading and transporting.

Load and transport pipes in straight, horizontal position with the full length supported (note that the sockets are unencumbered all around), avoid extreme pressure on the pipes (straps or other heavy materials).

Unload and handle pipes carefully and lay them in a straight, horizontal position (pay attention to positioning of the sockets), on a smooth surface (Figure 6, Figure 7).

Some sizes of pipes and all fittings are packed in carton boxes. Protect them from rain and moisture and store them in a dry place. It is recommended to store the pipes and fittings in their original sales packaging to protect them from damages.

Ultra Silent pipes are UV protected and can be stored outdoor for up to 2 years (depending on geographical location). The gasket material can withstand outdoor storage for up to 2 years and after this period must be replaced before installing. When using mechanical tools and machines (forklifts, cranes etc.) extra caution should be taken to prevent damages to the products.

Optical defects (external scratches and pigment changes etc.) have no influence on the quality and/or functionality of the system.

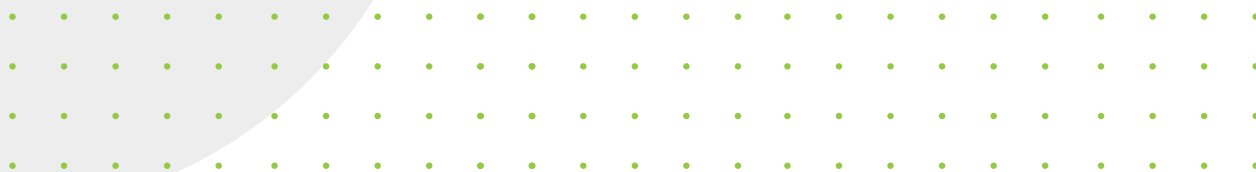

Our Product

We Make it Flow

Huliot Group is a global leader in advanced flow systems for commercial and residential buildings, bringing complete solutions that cover water supply, wastewater, and infrastructure.

We design, manufacture and market a full range of products that work together in harmony, to deliver a seamless and silent water flow experience, while respecting the environment and keeping it clean.



Domestic Drainage



Acoustic Drainage System



HT Drainage System



PP-R



Fire Protection Networks



Induction Technology



Manholes and inspection chambers



Grease & Fat separators

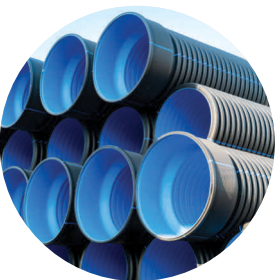

Stormwater management

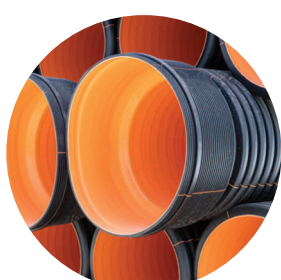

Drainage and sewerage

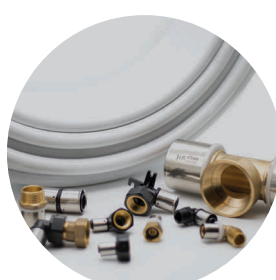

Multilayer System



PE-X(A) | PE-RT